

SELECTION CRITERIA FOR SAFETY VALVE

CALCULATION OF THE DISCHARGE CAPACITY (Ref. EN 13136:2013+A1)

The calculation of the minimum discharge capacity is linked to the system configuration on which the safety valve is installed, and to the cause of the safety valve opening, i.e.:

- **External heat sources** (Para. 6.2.1 - EN 13136:2013+A1). The minimum required discharge capacity is determined by the following formula:

$$Q_{md} = \frac{(3600 \times \phi \times A_{surf})}{h_{vap}} \quad [\text{kg/h}]$$

where:

- ϕ = density of heat flow rate, assumed to be 10 [kW/m²]
- A_{surf} = external surface area of the vessel [m²]
- h_{vap} = latent heat of vaporization of liquid at $p_o = 1,1 \times p_{set}$ [kJ/kg]
 - If p_o is higher than the saturated pressure of the refrigerant at critical temperature minus 5 °K, then h_{vap} shall be taken at critical temperature minus 5 °K
 - If the temperature at p_o is higher than the saturated temperature (superheated gas), then h_{vap} shall be taken at saturated condition

Note: vessels only containing refrigerant in the gas phase do not produce a continuous mass flow under an external hear impact.

- **Internal heat sources** (Para. 6.2.2 - EN 13136:2013+A1). The minimum required discharge capacity is determined by the following formula:

$$Q_{md} = \frac{(3600 \times Q_h)}{h_{vap}} \quad [\text{kg/h}]$$

where Q_h = rate of heat production [kW]

- **Increased pressure caused by a positive displacement compressor** (Para. 6.3 - EN 13136:2013+A1). The minimum required discharge capacity is determined by the following formula:

$$Q_{md} = 60 \times V \times n \times \rho_{10} \times \eta_v \quad [\text{kg/h}]$$

where:

- V = theoretical displacement of compressor [m³]
- n = rotational frequency of compressor [min⁻¹]
- ρ_{10} = vapour density of refrigerant, from the saturation curve at a temperature of 10 °C [kg/m³].
Table 1 provides the values of ρ_{10} for:
 - traditional HCFC and HFC refrigerants most commonly used
 - new HFO and HFC/HFO blend refrigerants
 - natural HC fluids
 (for R744, the ρ_0 vapour density value for CO₂ is indicated, from the saturation curve at a temperature of 0 °C [kg/m³]).
- η_v = volumetric efficiency of the compressor, estimated at suction pressure and discharge pressure equivalent to the safety valve setting.

SIZING OF SAFETY VALVES DESIGNED TO DISCHARGE GAS OR VAPOUR AT CRITICAL FLOW (Ref. EN ISO 4126-1: 2013 and EN 13136 :2013+A1)

Critical flow occurs when the back-pressure p_b (the pressure existing immediately at the outlet of the valve) is lower than or equal to the critical pressure:

$$p_b \leq p_o \times \left| \frac{2}{k+1} \right|^{\left(\frac{k}{k-1} \right)} \quad \text{[bar abs]}$$

where:

- p_o = actual relieving pressure, upstream the valve. It's equal to the set pressure plus overpressure; that is, the pressure increase over the set pressure at which the shutter has its total lift [bar abs]
- k = isentropic exponent of gas or vapour, based on the actual temperature and pressure conditions upstream of the valve during the discharge phase under full glow.

If k is unknown or difficult to determine, it is possible to assume:

$$p_{\text{critical}} = 0,5 \times p_o \quad \text{[bar abs]}$$

A valve that discharges to the atmosphere, is under in critical flow conditions.

To calculate the flow rate of a safety valve designed to discharge gas or vapour at critical flow, under specific operating conditions, use the following formulas, provided in Para. 7.2.5.2 of EN 13136:2013+A1.

$$Q_m = 0,2883 \times C \times A \times 0,9 \times K_d \times \sqrt{\frac{p_o}{v_o}} \quad \text{[kg/h]}$$

where:

- Q_m = calculated mass flow rate of safety valve [kg/h]
- A = calculated flow area of the safety valve [mm²]

$$\text{If } Q_{md} < Q_m < 1,25 \times Q_{md} \rightarrow Q_{md'} = Q_{md}$$

$$\text{If } Q_m > 1,25 \times Q_{md} \rightarrow Q_{md'} = Q_m / 1,25$$

where:

- $Q_{md'}$ = adjusted discharge capacity of safety valve, used for pressure drop calculation [kg/h]

The flow area A_c is calculated from the adjusted discharge capacity $Q_{md'}$ as follows:

$$A_c = 3,469 \times Q_{md'} / (C \times 0,9 \times K_d) \times \sqrt{\frac{v_o}{p_o}} \quad \text{[mm}^2\text{]}$$

where:

- K_d = certified discharge ratio of safety valve
- p_o = actual pressure upstream of the safety valve during discharge of the entire flow, see definition above. [bar abs]
- v_o = specific volume of gas or vapour at discharge conditions p_o and T_o , where T_o is the fluid temperature at valve inlet, defined by the user or by the designer [m³/kg]
- C = expansion rate as a function of the k coefficient in the isentropic equation calculated with the following formula:

$$C = 3,948 \times \sqrt{k \times \left| \frac{2}{k+1} \right|^{\left(\frac{k+1}{k-1} \right)}}$$

for this calculation, the value of k refers to a temperature of 25 °C. (Para. 7.2.3, EN 13136:2013+A1 standard).

Table 1 provides the k and C values for:

- traditional HCFC and HFC refrigerants most commonly used
- new HFO and HFC/HFO blend refrigerants
- natural HC fluids and R744

TABLE 1

Refrig.	R134a	R22	R32	R404A	R407C	R410A	R448A	R449A	R450A	R452A	R452B	R454A	R454B	R507	R513A	R1234yf	R1234ze	R290	R600	R600a	R744
PED Group	2	2	1	2	2	2	2	2	2	2	1	1	1	2	2	1	2	1	1	1	2
k	1,12	1,17	1,24	1,12	1,14	1,17	1,14	1,14	1,11	1,11	1,18	1,12	1,18	1,10	1,11	1,07	1,07	1,19	1,10	1,10	1,30
C	2,50	2,54	2,59	2,50	2,51	2,54	2,51	2,51	2,49	2,49	2,54	2,50	2,54	2,48	2,49	2,45	2,45	2,55	2,48	2,48	2,63
ρ [kg/m ³] (1)	20,23	28,82	30,23	41,66	27,45	41,92	30,63	31,11	18,49	40,62	33,48	26,12	32,44	44,03	23,59	24,27	16,45	13,78	3,87	5,87	97,60

- (1) ρ_{10} [kg/m³] for all refrigerant, excluded R744
 ρ_0 [kg/m³] for R744

INSTALLATION OF A SAFETY VALVE (Ref. EN 13136:2013+A1)

As far as the installation of safety valves is concerned, remember these basic points:

- The fitting between the valve and the equipment to be protected must be as short as possible. Furthermore, the cross-section of the piping must not be smaller than the valve inlet. In any case, EN 13136:2013+A1 states that the pressure drop between the protected vessel and the safety valve, at discharge capacity, **shall not exceed 3% of actual relieving pressure p_0** , including any accessory on the line.
- The location selected for installation of the safety valve must consider that valve operation involves the discharge of the refrigerant fluid under pressure, sometimes at high temperature. Where there is the risk of causing injuries to people nearby, exhaust piping must be provided, sized so as to not compromise valve operation. EN 13136:2013+A1 states that this piping **must not generate, at discharge capacity, a back-pressure exceeding 10% of actual relieving pressure p_0** , for unbalanced, conventional valves. In the event of multiple valves installed in parallel, it is highly recommended that each valve be fit with a dedicated exhaust line rather than a single manifold for all of the valves. The risk of the latter solution is to create an overpressure in the manifold determined when a valve discharges. This overpressure can modify the operating characteristics of all the other valves installed in parallel.

Pressure losses in the upstream line

To calculate the pressure losses in the upstream line (between vessel and safety valve) refer to Section 7.4 of EN 13136:2013+A1.

The upstream pressure loss is given by:

$$\Delta p_{in} = 0,032 \times \left[\frac{A_c}{A_{in}} \times C \times K_{dr} \right]^2 \times \zeta \times p_0 \quad [\text{bar}]$$

where:

- A_c = calculated flow area from the minimum required discharge capacity Q_{md} [mm²]
- A_{in} = cross-section area of inlet tube to valve [mm²]
- $K_{dr} = K_d \times 0,9$, reduced discharge coefficient
- C = expansion rate as a function of the k coefficient in the isentropic equation for the refrigerant fluid
- ζ = sum of the of pressure loss coefficients ξ_n of the individual components and piping

The coefficients ξ_n refer to:

- pipe element losses, such as fittings and elbows
- valve losses
- losses along the piping

and are listed in standard EN 13136:2013+A1, Table A.4.

To ensure correct operation of safety valve $\Delta p_{in} \leq 0,03 \times p_0 \Delta$ [bar]

Pressure losses in the downstream line

To calculate the pressure losses in the downstream line (between safety valve and atmosphere) refer to Section 7.4 of EN 13136:2013+A1.

The downstream pressure loss is given by:

$$\Delta p_{out} = p_1 - p_2 \dots [\text{bar}]$$

$$p_1 = \sqrt{0,064 \times \zeta \times \left(\frac{A_c}{A_{out}} \times C \times K_{dr} \times p_0 \right)^2 + p_2^2} \quad [\text{barabs}]$$

where:

- P_1 = inlet pressure to discharge line [bar abs]
- P_2 = outlet pressure to discharge line, equal to atmospheric pressure [bar abs]
- A_c = calculated flow area from the minimum required discharge capacity Q_{md} [mm²]
- A_{out} = cross-section area of valve outlet pipe [mm²]
- $K_{dr} = K_d \times 0.9$, reduced discharge coefficient
- C = expansion rate as a function of the k coefficient in the isentropic equation for the refrigerant fluid
- p_0 = actual pressure downstream of the safety valve during discharge of the entire flow [bar abs].
- ξ = sum of the of pressure loss coefficients ξ_n of the piping

The coefficients ξ_n refer to:

- pipe element losses, bends
- losses along the piping

and are listed in standard EN 13136:2013+A1, Table A.4..

To ensure correct operation of safety valve $\Delta p_{out} \leq 0,10 \times p_0 \Delta$ [bar]

EXAMPLE 1: Calculation of the flow rate (Q_{md}) and selection of the safety valve (Increased pressure caused by a positive displacement compressor)

Compressor data

- Bore: 82.5 mm
- Stroke: 69.8 mm
- Number of cylinders 4
- Rotational frequency 1450 rpm
- Clearance 4%
- Refrigerant fluid R407C

The theoretical displacement of the compressor is:

$$V = \frac{\pi}{4} \times 0,0825^2 \times 0,0698 \times 4 = 0,00149 [\text{m}^3]$$

Maximum allowable pressure of the liquid condenser / receiver: $P_S = 25$ bar

Set pressure of the safety valve that must be installed on the upper crown of the condenser housing: $p_{set} = 25$ bar

$$p_0 = p_{set} \times \left(1 + \frac{10}{100}\right) + 1 = 28,5 \quad [\text{bar abs}]$$

Operating conditions of compressor at the safety valve discharge:

Condensation temperature: $+65.2$ °C (28.5 bar abs)

Evaporation temperature: $+10$ °C (6.33 bar abs)

These conditions, defined by the designer, are assumed to be the most unfavourable for the safety valve due to operating faults such as:

- Movement errors
- Non-operation of automatic safety devices that should have been triggered prior to the safety valve due to failures or other reasons

For cautionary reasons, ignoring the vapour overheating at the outlet of the evaporator, the volumetric efficiency of compressor is:

$$\eta_v = 1 - 0,04 \times \frac{p_{discharge}}{p_{suction}} = 1 - 0,04 \times \frac{28,5}{6,33} = 0,82$$

and the minimum required discharge capacity is:

$$Q_{md} = 60 \times V \times n \times \rho_{10} \times \eta_v = 60 \times 0,00149 \times 1450 \times 27,45 \times 0,82 = 2918 \quad [\text{kg/h}]$$

where $\rho_{10} = 27.45$ [kg/m³], saturated vapour density of R407C at a temperature of 10 °C

Choosing a safety valve in series 3065 its mass flow rate:

$$Q_m = 0,2883 \times C \times A \times 0,9 \times K_d \times \sqrt{\frac{p_0}{v_0}} =$$

$$0,2883 \times 2,51 \times 132,7 \times 0,9 \times 0,87 \times \sqrt{\frac{28,5}{0,0069}} = 4832 \quad \left[\frac{\text{kg}}{\text{h}}\right]$$

where:

- $C = 2.51$, corresponding to k exponent for R407C, equal to 1.14, according to Table 7
- $K_d = 0.87$, certified discharge ratio of safety valve 3065/4
- $v_0 = 0.0069$ [m³/kg], specific volume of the saturated vapour upstream of the safety valve during operation. This value refers to the following operating conditions upstream of the valve:
 - Pressure, $p_0 = 28.5$ [bar abs]
 - Temperature, $T_0 = 65.2$ [°C]

The adjusted discharge capacity of the safety valve, used for pressure drop calculation is:

$$Q_m > 1,25 \times Q_{md} = 4832 > 1,25 \times 2918 \quad \rightarrow \quad Q_{md'} = \frac{4832}{1,25} = 3865 \quad \left[\frac{\text{kg}}{\text{h}}\right]$$

The flow area A_c calculated with the adjusted discharge capacity $Q_{md'}$ is:

$$A_c = 3,469 \times \frac{Q_{md'}}{(C \times 0,9 \times K_d)} \times \sqrt{\frac{v_0}{p_0}} =$$

$$3,469 \times \frac{3865}{(2,51 \times 0,9 \times 0,87)} \times \sqrt{\frac{0,0069}{28,5}} = 106 \quad [\text{mm}^2]$$

Verification of the system upstream the safety valve

Assuming the valve installed is 3065/4C250, using a steel fitting with the following characteristics:

- $d_{in} = 17$ [mm] , fitting inside diameter
- $A_{in} = 227$ [mm²] fitting inside cross-section area
- $L = 60$ [mm] , fitting length
- Condenser connection: Flush with the housing and with a sharp edge

The following information is taken from Table A.4 in standard EN 13136:2013+A1:

- ξ_1 (inlet) = 0.25
- ξ_2 (length) = $\lambda \times L / d_{in} = 0.02 \times 60 / 17 = 0.07$
with $\lambda = 0.02$ for steel pipe
- $\xi_T = \xi_1 + \xi_2 = 0.25 + 0.07 = 0.32$

Between the safety valve and the steel fitting, a shut-off valve type 3064N/44 is installed.

The main characteristics of this valve are:

- $d_R = 13$ [mm] , inside valve diameter
- $A_R = 132.7$ [mm²] , inside valve cross-section area
- $kv = 10$ [m³/h] , valve kv coefficient

The pressure loss coefficient ξ_R of the shut-off valve is given by:

$$\xi_R = 2,592 \times \left[\frac{132,7}{10} \right]^2 \times 10^{-3} = 0,45$$

Total loss coefficient: $\xi_T + \xi_R = 0,77$

Recalling the previously calculated flow area A_c , the characteristics of safety valve 3065/4 and refrigerant fluid R407C:

- $A_c = 106$ [mm²]
- $K_{dr} = 0.89 \times 0.9 = 0.801$
- $C = 2.51$

The pressure loss is given by:

$$\frac{\Delta p_{in}}{p_o} = 0,032 \times \left[\frac{106}{227} \times 2,51 \times 0,801 \right]^2 \times 0,77 = 0,022$$

The pressure loss value obtained is admissible because it is lower than the value of 0.03 indicated in standard EN 13136:2013+A1.

Verification of system downstream the safety valve

Suppose it is necessary to construct a discharge pipe on safety valve 3065/4C250, using 1" gas pipe with the following characteristics:

- $d_{out} = 30$ [mm] , inside pipe diameter
- $A_{out} = 707$ [mm²] , inside pipe cross-section area
- $L = 3000$ [mm] , pipe length
- 90° elbow with bending radius, R, equal to three times external diameter of pipe

The following information is taken from Table A.4 in standard EN 13136:2013+A1:

- ξ_1 (elbow) = 0.25
- ξ_2 (length) = $\lambda \times L / d_{out} = 0.02 \times 3000 / 30 = 2$ where $\lambda = 0.02$ for steel pipe
- $\xi_T = \xi_1 + \xi_2 = 0,25 + 2 = 2,25$

The pressure loss is given by:

$$p_1 = \sqrt{0,064 \times 2,25 \times \left(\left(\frac{106}{707} \right) \times 2,51 \times 0,801 \times 28,5 \right)^2 + 1^2} = 3,41 \text{ [bar]}$$

$$= \frac{\Delta p_{\text{out}}}{p_o} = \frac{3,41 - 1}{28,5} = 0,086$$

The pressure loss value obtained is admissible because it is lower than the value of 0.10 indicated in standard EN 13136:2013+A1.

**EXAMPLE 2: Calculation of the flow rate ($Q_{md'}$) and selection of the safety valve
(Increase in pressure caused by internal heat source)**

Data for the liquid receiver

Refrigerant fluid	R404A
Pressure equipment 300 l liquid receiver	
External surface area of the vessel	3.2 m ²
PS of the vessel	28 bar

Calculation of the valve discharge pressure is:

$$p_0 = (p_{\text{set}} \times 1,1) + 1 = (28 \times 1,1) + 1 = 31,8 \quad \text{[bar abs]}$$

Calculation of the minimum required discharge capacity for the external heat source considering that there are flammable substances in such quantities as to feed a fire near the vessel to be protected.

$$Q_{md} = \frac{(3600 \times \phi \times A_{\text{surf}})}{h_{\text{vap}}} = \frac{(3600 \times 10 \times 3,2)}{67,28} = 1712 \text{ [kg/h]}$$

where:

- ϕ = density of heat flow rate, assumed to be 10 [kW/m²]
- A_{surf} = external surface area of the vessel [m²]
- h_{vap} = latent heat of vaporization of R404A at pressure, p_o [kJ/kg]

Choosing a safety valve in series 3061 its mass flow rate:

$$Q_m = 0,2883 \times C \times A \times 0,9 \times K_d \times \sqrt{\frac{p_o}{v_o}}$$

$$0,2883 \times 2,5 \times 44,2 \times 0,9 \times 0,89 \times \sqrt{\frac{31,8}{0,0042}} = 2220 \left[\frac{\text{kg}}{\text{h}} \right]$$

where:

- $C = 2.5$, corresponding to k exponent for R404A, equal to 1.12, according to Table 7
- $K_d = 0.89$, certified discharge ratio of safety valve 3061/4
- $v_o = 0.0042$ [m³/kg], specific volume of the saturated vapour upstream of the safety valve during operation. This value refers to the following operating conditions upstream of the valve:
 - Pressure, $p_o = 31,8$ [bar abs]
 - Temperature, $T_o = 64,7$ [°C]

The adjusted discharge capacity of the safety valve, used for pressure drop calculation is:

$$Q_m > 1,25 \times Q_{md} = 2220 > 1,25 \times 1712 \quad \rightarrow \quad Q_{md'} = \frac{2220}{1,25} = 1776 \left[\frac{\text{kg}}{\text{h}} \right]$$

The flow area A_c calculated with the adjusted discharge capacity Q_{md}' is:

$$A_c = 3,469 \times Q_{md}' / (C \times 0,9 \times K_d) \times \sqrt{\frac{v_o}{p_o}} =$$

$$3,469 \times 1776 / (2,5 \times 0,9 \times 0,89) \times \sqrt{0,0042 / 31,8} = 35,4 \text{ [mm}^2\text{]}$$

Verification of the system upstream the safety valve

Assuming the valve installed is 3061/4C280, using a steel fitting with the following characteristics:

- $d_{in} = 17$ [mm] , fitting inside diameter
- $A_{in} = 227$ [mm²] fitting inside cross-section area
- $L = 60$ [mm] , fitting length
- Receiver connection: Flush with the housing and with a sharp edge

The following data is taken from Table A.4:

- ξ_1 (inlet) = 0,25
- ξ_2 (length) = $\lambda \times L / d_{in} = 0,02 \times 60 / 17 = 0,07$
with $\lambda = 0.02$ for steel pipe
- $\xi_T = \xi_1 + \xi_2 = 0,25 + 0,07 = 0,32$

Between the valve and the fitting, an exchange valve (type 3032N/44) has been installed.

The main characteristics of this valve are:

- $d_R = 13$ [mm] , inside valve diameter
- $A_R = 132.7$ [mm²], inside valve cross-section area
- $kv = 3.3$ [m³/h] , valve kv coefficient

The pressure loss coefficient ξ_R of the exchange valve is given by:

$$\xi_R = 2,592 \times \left[\frac{132,7}{3,3} \right]^2 \times 10^{-3} = 4,19$$

Total loss coefficient: $\xi_T + \xi_R = 4.51$

Recalling the previously calculated cross-section, the characteristics of safety valve 3061/4 and refrigerant fluid R404A:

- $A_c = 35,4$ [mm²]
- $K_{dr} = 0,89 \times 0,9 = 0,801$
- $C = 2,50$

The pressure loss is given by:

$$\frac{\Delta p_{in}}{p_o} = 0,032 \times \left[\frac{35,4}{227} \times 2,50 \times 0,801 \right]^2 \times 4,51 = 0,014$$

The pressure loss value obtained is admissible because it is lower than the value of 0.03 indicated in standard EN 13136:2013+A1.

The calculations shown in the previous examples 1 / 2 and the results obtained are:

- The minimum discharge capacity
 - The minimum cross-sectional area of the valve orifice
 - The pressure loss in the upstream line
 - The pressure loss in the downstream line
- can be performed using the selection software.

TABLE 2 – Pressure loss coefficients of a single component ζ_n

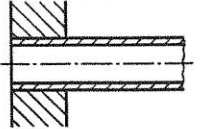
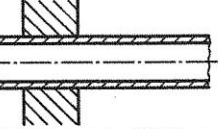
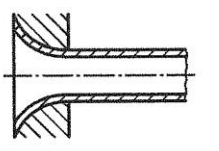
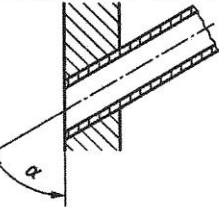
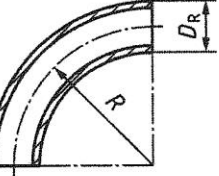
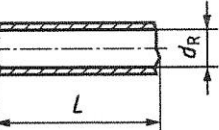
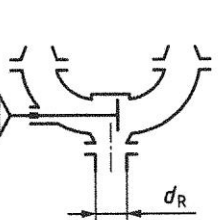
Pipe elements		Flush connection	Very sharp edged $\zeta_n = 0,5$ Broken edge $\zeta_n = 0,25$
		Inserted connection	Very sharp edged $\zeta_n = 1$ Broken edge $\zeta_n = 0,56$
		Flared connection	According to the radius: Between $\zeta_n = 0,005$ and $\zeta_n = 0,06$ normally $\zeta_n = 0,05$ is used
		Angled flush connection	$\zeta_n = 0,5 + 0,3 \cos \alpha + 0,2 \cos^2 \alpha$
		Pipe bend 90°	$R = 2D_R$ $\zeta_n = 0,3$ $R = 3D_R$ $\zeta_n = 0,25$ $R = 4D_R$ $\zeta_n = 0,23$ $R = 5D_R$ $\zeta_n = 0,18$
		Straight pipe	$\zeta_n = \lambda \times \frac{L}{d_R}$ Steel pipe $\lambda = 0,02$
		Valves and changeover valves	$\zeta = 2,592 \times \left[\frac{A_R}{K_{vs}} \right]^2 \times 10^{-3}$ $A_r = \frac{\pi \times d_R^2}{4}$ K_{vs} or ζ shall be indicated by the manufacturer